

Floating Reamer Holder



At a glance

- Multi-directional movements allow float around workpiece centre (the reamer will accurately follow a correctly centred hole where the drill has subsequently wandered)
- Adjustable counter pressure against float direction
- Automatic centring of reamer
- Radial and axial spring pressures are adjustable to suit reamer size and conditions
- With integrated coolant feeding (VDI)
- Available with
 - ANGST-Flex or ESX (ER) collets
 - All common shanks such as cylindrical, cylindrical with flat (Weldon), DIN 69880 / VDI 3425, SK DIN 69871, BT (Japan Standard MAS 403), ISO Caterpillar and morse tapered
- Heavy-duty and durable Swiss quality products

In addition to the normal float directions incorporated in reamer holders currently available, as shown in Fig.1 and 2, this toolholder provides a pivoting float around the workpiece centre as shown in Fig. 3. This innovation also guarantees true size reaming when the drill has run off centre.

Built into this toolholder is a centring device through which the front part of the floating holder is automatically held on centre thus ensuring that the start of the reaming operation, whether vertical or horizontal, is always in the correct central position.

General setting recommendations:

- **Strong pendulum resistance**
Set screw S on III
Fully tighten screw H
- **Medium pendulum resistance**
Set screw S on II
Loosen tighten screw H
- **Weak pendulum resistance**
Set screw S on I
Loosen tighten screw H

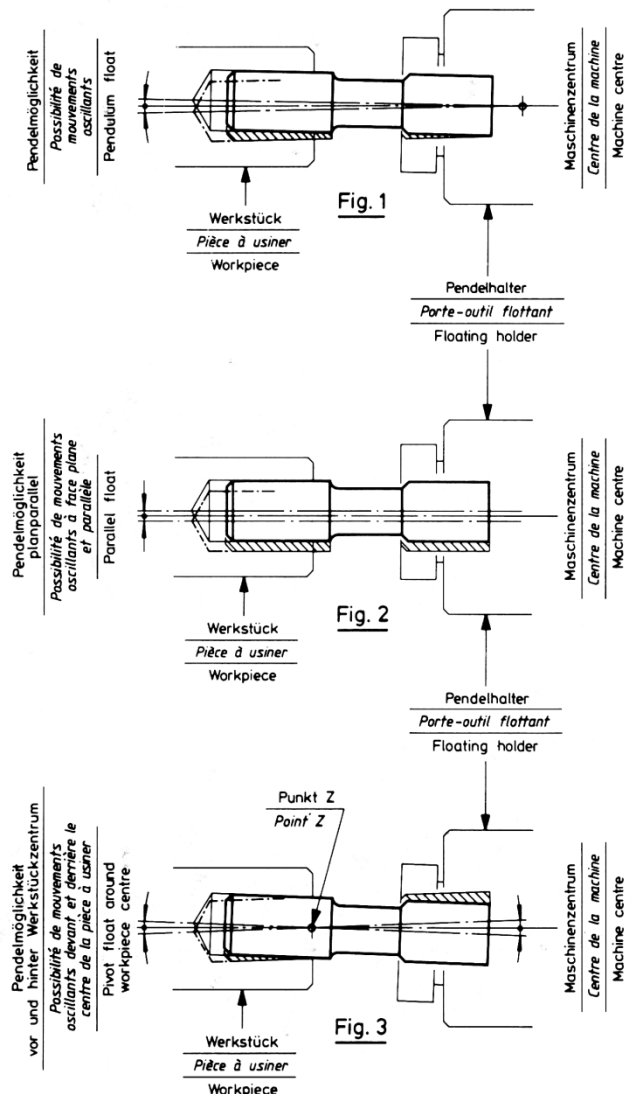

The centralising spring pressure (P) within the front part of the toolholder can be pre-set, or adjusted, according to reaming conditions and size of reamer. Spring pressure adjustments are made by turning the knurled ring and setting the locking screw (S) on Pos. I, II or III. Similarly, the back spring pressure (F) can be adjusted with the key provided by turning the screw.

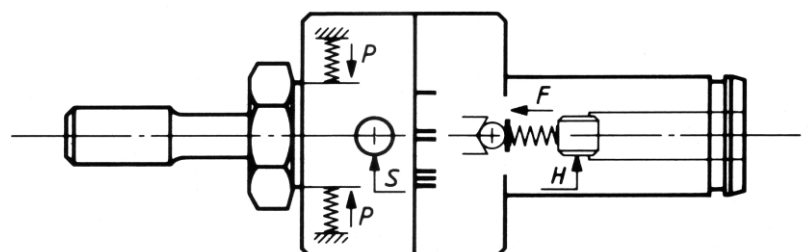

Type ANGST Flex

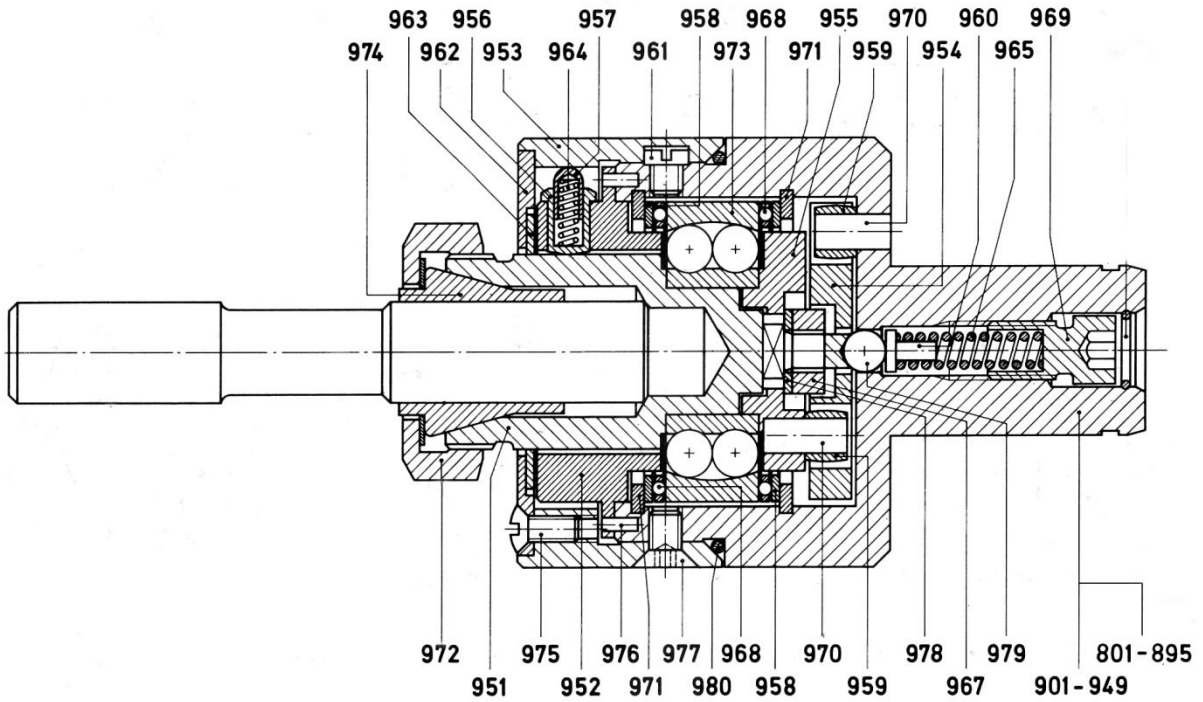

Type ESX (ER)

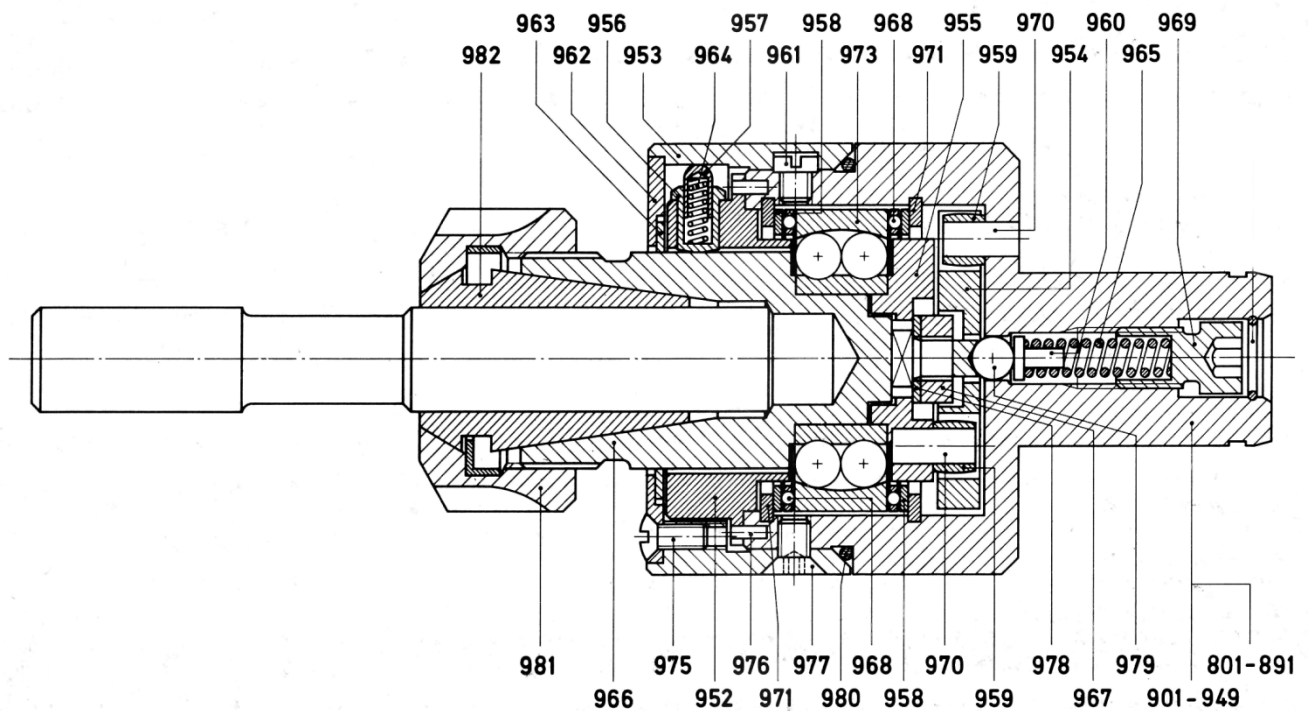

Morse taper inserts for reamer shanks type ANGST Flex

Type ANGST Flex	1		2		3		4	
	No.	X	No.	X	No.	X	No.	X
Inserts for morse taper shanks	No.	X	No.	X	No.	X	No.	X
MK 1	-	-	36-2121	44	-	-	-	-
MK 2	-	-	-	-	-	-	36-4122	47
MK 3	-	-	-	-	-	-	36-4123	66
Nut for taper insert	-	-	36-2127	-	-	-	36-4127	-

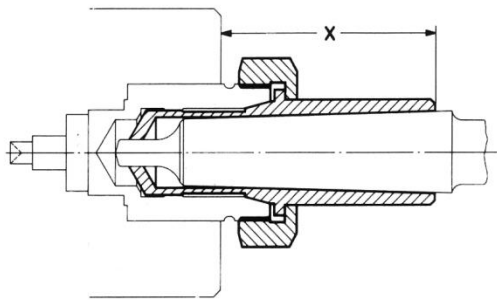

Morse taper inserts for reamer shanks type ESX (ER)

Type ESX	1		2		3		4	
	No.	X	No.	X	No.	X	No.	X
Inserts for morse taper shanks	No.	X	No.	X	No.	X	No.	X
MK 1	-	-	36-2191	44	-	-	-	-
MK 2	-	-	-	-	-	-	36-4192	47
MK 3	-	-	-	-	-	-	36-4193	66
Nut for taper insert	-	-	36-2197	-	-	-	36-4197	-

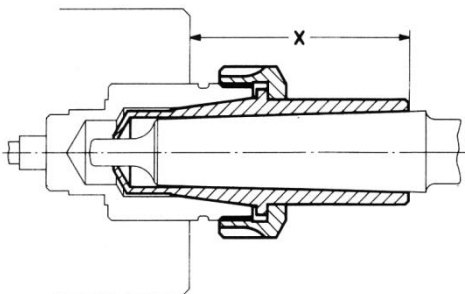

Floating reamer holder Type ANGST Flex 1 – Gripping Capacity $\varnothing G = 2-6.5$

Shanks	$\varnothing d \times l$	No.	$\varnothing A$	B
Cylindrical Fig. 6	14 x 25	36-1001	-	34
	$\frac{3}{8}$ " x 30	36-1002	-	34
	$\frac{3}{4}$ " x 30	36-1003	-	34
	$\frac{3}{4}$ " x 50	36-1004	-	34
	20 x 30	36-1005	-	34
	20 x 50	36-1006	-	34
	25 x 50	36-1007	-	34
	1" x 50	36-1008	-	34
	30 x 60	36-1009	-	34
VDI 3425 Fig. 7	16 x 32	36-1013	40	43
	20 x 40	36-1014	50	43
	30 x 55	36-1015	68	45
Cylindrical with flat	16 x 50	36-1035	-	34
	20 x 50	36-1036	-	34
	25 x 50	36-1037	-	34
BT Fig. 8	BT 40	36-1216	63	61
DIN 69 871 A Fig. 8	SK 40	36-1236	63.5	53
	SK 45	36-1237	82.5	53
Morse taper Fig. 9	MK 2	36-1402	-	34
	MK 3	36-1403	-	34

Collets capacities (Fig. A)			
No.	$\varnothing D$	No.	$\varnothing D$
33-1625	$\varnothing 2.5-2$	33-1650	$\varnothing 5-4$
33-1630	$\varnothing 3-2.5$	33-1660	$\varnothing 6-5$
33-1635	$\varnothing 3.5-3$	33-1665	$\varnothing 6.5-5.5$
33-1640	$\varnothing 4-3.5$		

Set of collets	No.	$\varnothing D$
7 Collets as per list (33-1625 to 33-1665)	33-1600	$\varnothing 2.5-2$ bis $\varnothing 6.5-5.5$

Fig. 6

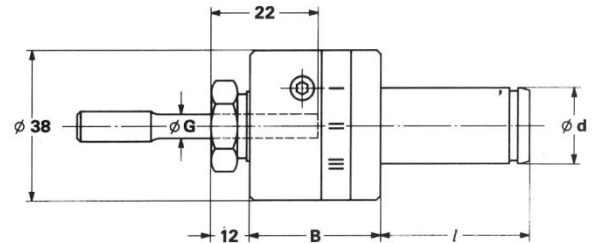

Fig. 7

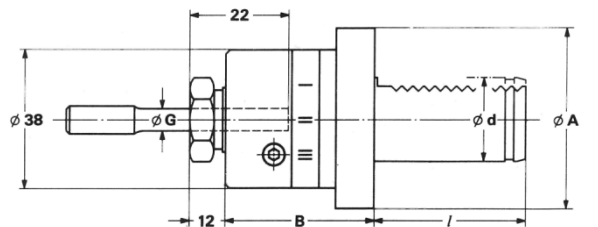

Fig. 8

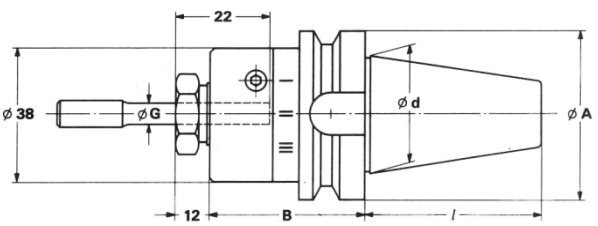

Fig. 9

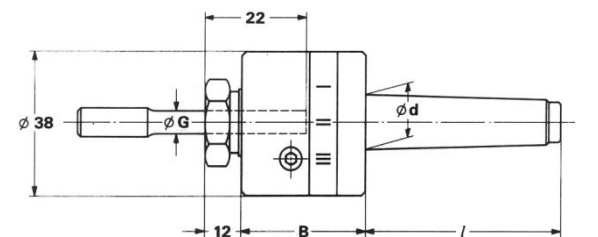
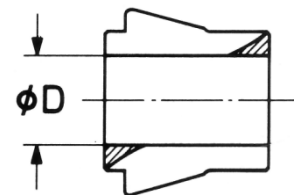

Fig. A



Floating reamer holder Type ESX 12 (ER 11) – Gripping Capacity $\varnothing G = 2-7$

Shanks	$\varnothing d \times l$	No.	$\varnothing A$	B
Cylindrical Fig. 10	14 x 25	36-1051	-	34
	$\frac{3}{8}$ " x 30	36-1052	-	34
	$\frac{1}{2}$ " x 30	36-1053	-	34
	$\frac{3}{4}$ " x 50	36-1054	-	34
	20 x 30	36-1055	-	34
	20 x 50	36-1056	-	34
	25 x 50	36-1057	-	34
	1" x 50	36-1058	-	34
VDI 3425 Fig. 11	16 x 32	36-1063	40	43
	20 x 40	36-1064	50	43
	30 x 55	36-1065	68	45
Cylindrical with flat	16 x 50	36-1085	-	34
	20 x 50	36-1086	-	34
	25 x 50	36-1087	-	34
BT Fig. 12	BT 40	36-1266	63	61
DIN 69 871 A Fig. 12	SK 40	36-1286	63.5	53
	SK 45	36-1287	82.5	53
Morse taper Fig. 13	MK 2	36-1452	-	34
	MK 3	36-1453	-	34

Collets capacities (Fig. B)			
No.	$\varnothing D$	No.	$\varnothing D$
38-1625	$\varnothing 2.5-2$	38-1650	$\varnothing 5-4$
38-1630	$\varnothing 3-2.5$	38-1660	$\varnothing 6-5$
38-1640	$\varnothing 4-3$	38-1670	$\varnothing 7-6$

Set of collets	No.	$\varnothing D$
6 Collets as per list (38-1625 to 38-1670)	38-1600	$\varnothing 2.5-2$ bis $\varnothing 7-6$

Fig. 10

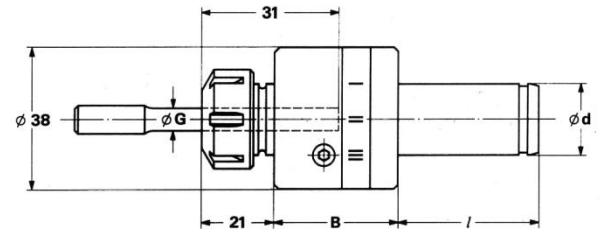

Fig. 11

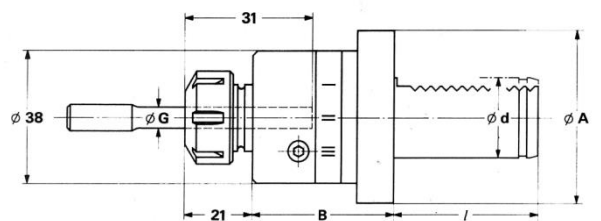

Fig. 12

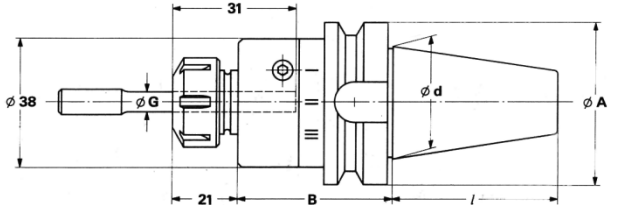

Fig. 13

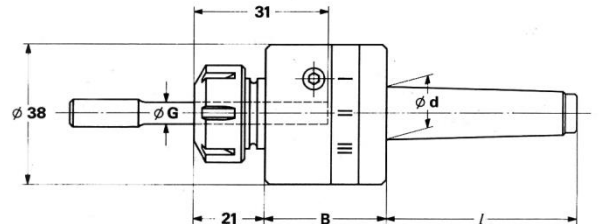
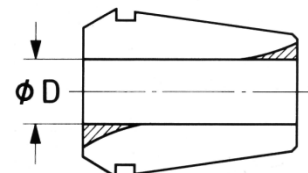

Fig. B



Floating reamer holder Type ANGST Flex 2 – Gripping capacity $\varnothing G = 3-12$

Shanks	$\varnothing d \times l$	No.	$\varnothing A$	B
Cylindrical Fig. 14	$\frac{5}{8}'' \times 30$	36-2002	-	44
	$\frac{3}{4}'' \times 30$	36-2003	-	44
	$\frac{3}{4}'' \times 50$	36-2004	-	44
	20 x 30	36-2005	-	44
	20 x 50	36-2006	-	44
	25 x 50	36-2007	-	44
	1" x 50	36-2008	-	44
VDI 3425 Fig. 15	16 x 32	36-2013	50	52
	20 x 40	36-2014	50	52
	25 x 48	36-2020	58	54
	30 x 55	36-2015	68	54
	40 x 63	36-2016	83	54
Cylindrical with flat	16 x 50	36-2035	-	44
	20 x 50	36-2036	-	44
	25 x 50	36-2037	-	44
	32 x 60	36-2038	-	44
	40 x 70	36-2039	-	44
BT Fig. 16	BT 40	36-2216	63	71
	BT 45	36-2217	85	77
	BT 50	36-2218	100	82
DIN 69 871 A Fig. 16	SK 40	36-2236	63.5	63
	SK 45	36-2237	82.5	63
Morse taper Fig. 17	MK 2	36-2402	-	44
	MK 3	36-2403	-	44

Collets capacities (Fig. A)			
No.	$\varnothing D$	No.	$\varnothing D$
33-2635	$\varnothing 3.5-3$	33-2680	$\varnothing 8-7$
33-2640	$\varnothing 4-3.5$	33-2690	$\varnothing 9-8$
33-2650	$\varnothing 5-4$	33-2700	$\varnothing 10-9$
33-2660	$\varnothing 6-5$	33-2710	$\varnothing 11-10$
33-2670	$\varnothing 7-6$	33-2720	$\varnothing 12-11$

Set of collets	No.	$\varnothing D$
10 Collets as per list (33-2635 to 33-2720)	33-2600	$\varnothing 3.5-3$
		bis
		$\varnothing 12-11$

Fig. 14

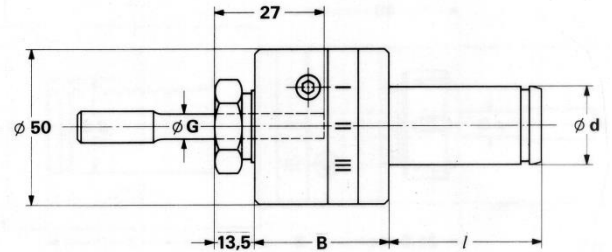

Fig. 15

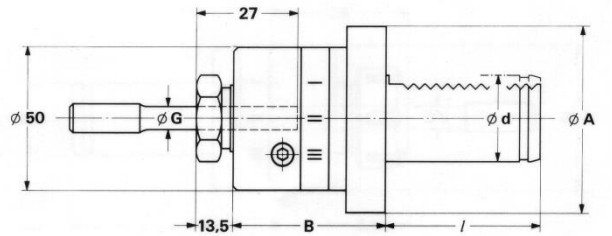

Fig. 16

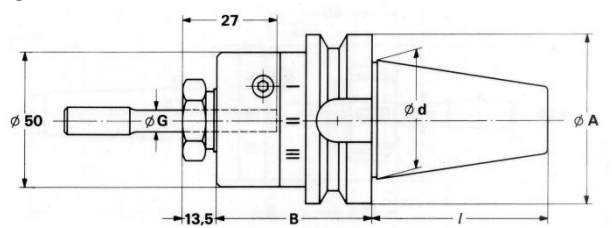

Fig. 17

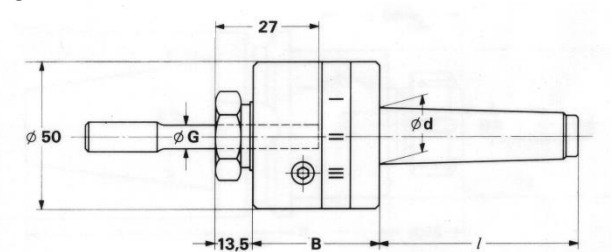
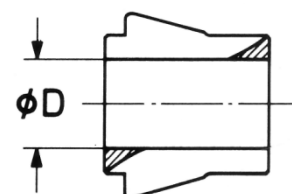

Fig. A



Floating reamer holder Type ESX 20 (ER 20) – Gripping capacity $\varnothing G = 3-12$

Shanks	$\varnothing d \times l$	No.	$\varnothing A$	B
Cylindrical Fig. 18	$\frac{3}{8}'' \times 30$	36-2052	-	44
	$\frac{1}{2}'' \times 30$	36-2053	-	44
	$\frac{3}{4}'' \times 50$	36-2054	-	44
	20 x 30	36-2055	-	44
	20 x 50	36-2056	-	44
	25 x 50	36-2057	-	44
	1" x 50	36-2058	-	44
	1 1/2" x 70	36-2061		44
VDI 3425 Fig. 19	16 x 32	36-2063	50	52
	20 x 40	36-2064	50	52
	25 x 48	36-2070	58	54
	30 x 55	36-2065	68	54
	40 x 63	36-2066	83	54
Cylindrical with flat	16 x 50	36-2085	-	44
	20 x 50	36-2086	-	44
	25 x 50	36-2087	-	44
	32 x 60	36-2088	-	44
	40 x 70	36-2089	-	44
BT Fig. 20	BT 40	36-2266	63	71
	BT 50	36-2268	100	82
DIN 69 871 A Fig. 20	SK 40	36-2286	63.5	63
	SK 45	36-2287	82.5	63
Morse taper Fig. 21	MK 2	36-2452	-	44
	MK 3	36-2453	-	44

Collets capacities (Fig. B)			
No.	$\varnothing D$	No.	$\varnothing D$
38-2640	$\varnothing 4-3$	38-2690	$\varnothing 9-8$
38-2650	$\varnothing 5-4$	38-2700	$\varnothing 10-9$
38-2660	$\varnothing 6-5$	38-2710	$\varnothing 11-10$
38-2670	$\varnothing 7-6$	38-2720	$\varnothing 12-11$
38-2680	$\varnothing 8-7$		

Set of collets	No.	$\varnothing D$
9 Collets as per list (38-2640 to 38-2720)	38-2600	$\varnothing 4-3$
		bis
		$\varnothing 12-11$

Fig. 18

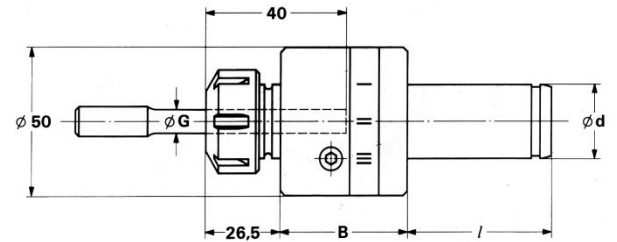

Fig. 19

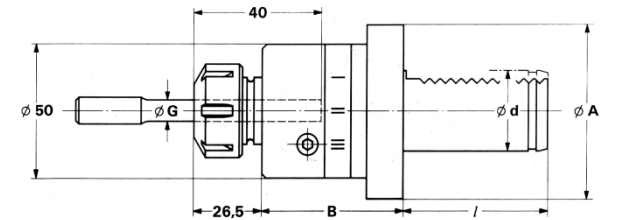

Fig. 20

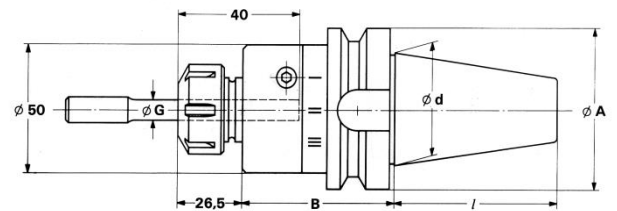

Fig. 21

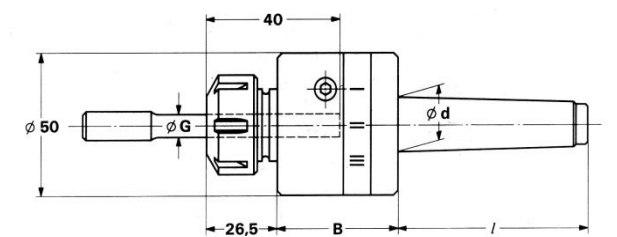
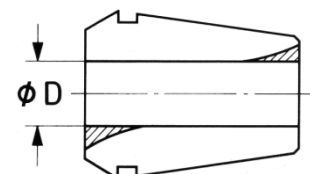

Fig. B



Floating reamer holder Type ANGST Flex 4 – Gripping capacity $\varnothing G = 6-20$

Shanks	$\varnothing d \times l$	No.	$\varnothing A$	B
Cylindrical Fig. 30	25 x 50	36-4007	-	63
	1" x 50	36-4008	-	63
	30 x 60	36-4009	-	63
	1 1/4" x 60	36-4010	-	63
	1 1/2" x 70	36-4011	-	63
VDI 3425 Fig. 31	40 x 70	36-4012	-	63
	30 x 55	36-4015	84	72
	40 x 63	36-4016	84	72
Cylindrical with flat	50 x 78	36-4017	98	72
	25 x 50	36-4037	-	63
	32 x 60	36-4038	-	63
BT Fig. 32	40 x 70	36-4039	-	63
	BT 40	36-4216	63	90
BT Fig. 32	BT 50	36-4218	100	101
	DIN 69 871 A	SK 40	36-4236	63.5
DIN 69 871 A Fig. 32	SK 45	36-4237	82.5	99
	Morse taper Fig. 33	MK 3	36-4403	-
MK 4		36-4404	-	63

Collets capacities (Fig. A)			
No.	$\varnothing D$	No.	$\varnothing D$
33-4670	$\varnothing 7-6$	33-2740	$\varnothing 14-12$
33-4680	$\varnothing 8-7$	33-4760	$\varnothing 16-14$
33-4690	$\varnothing 9-8$	33-4780	$\varnothing 18-16$
33-4700	$\varnothing 10-9$	33-4800	$\varnothing 20-18$
33-4720	$\varnothing 12-10$		

Set of collets	No.	$\varnothing D$
9 Collets as per list (33-4670 to 33-4800)	33-4600	$\varnothing 7-6$ bis $\varnothing 20-18$

Fig. 30

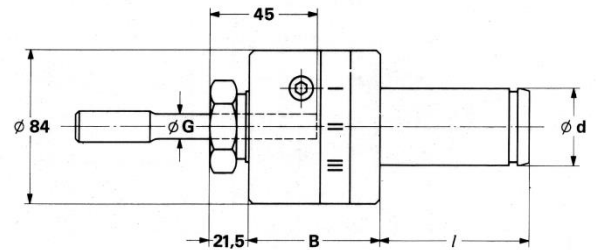

Fig. 31

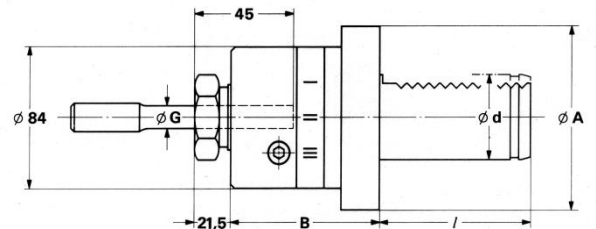

Fig. 32

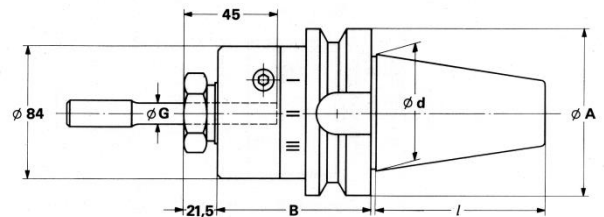

Fig. 33

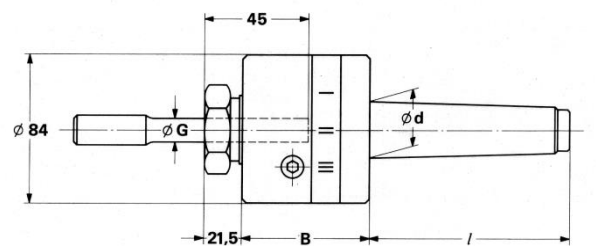
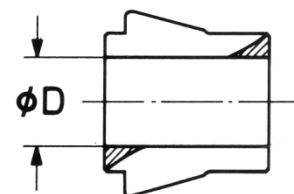

Fig. A



Floating reamer holder Type ESX 32 (ER 32) – Gripping capacity $\varnothing G = 6-20$

Shanks	$\varnothing d \times l$	No.	$\varnothing A$	B
Cylindrical Fig. 34	25 x 50	36-4057	-	63
	1" x 50	36-4058	-	63
	30 x 60	36-4059	-	63
	1 1/4" x 60	36-4060	-	63
	1 1/2" x 70	36-4061	-	63
VDI 3425 Fig. 35	40 x 70	36-4062	-	63
	30 x 55	36-4065	84	72
	40 x 63	36-4066	84	72
Cylindrical with flat	50 x 78	36-4067	98	72
	25 x 50	36-4087	-	63
	32 x 60	36-4088	-	63
BT Fig. 36	40 x 70	36-4089	-	63
	BT 40	36-4266	63	90
BT Fig. 36	BT 50	36-4268	100	101
	DIN 69 871 A	SK 40	36-4286	63.5
DIN 69 871 A Fig. 36	SK 45	36-4287	82.5	99
	Morse taper Fig. 37	MK 3	36-4453	-
MK 4		36-4454	-	63

Collets capacities (Fig. B)			
No.	$\varnothing D$	No.	$\varnothing D$
38-4670	$\varnothing 7-6$	38-4740	$\varnothing 14-13$
38-4680	$\varnothing 8-7$	38-4750	$\varnothing 15-14$
38-4690	$\varnothing 9-8$	38-4760	$\varnothing 16-15$
38-4700	$\varnothing 10-9$	38-4770	$\varnothing 17-16$
38-4710	$\varnothing 11-10$	38-4780	$\varnothing 18-17$
38-4720	$\varnothing 12-11$	38-4790	$\varnothing 19-18$
38-4730	$\varnothing 13-12$	38-4800	$\varnothing 20-19$

Set of collets	No.	$\varnothing D$
14 Collets as per list (38-4670 to 38-4800)	38-4600	$\varnothing 7-6$ bis $\varnothing 20-19$

Fig. 34

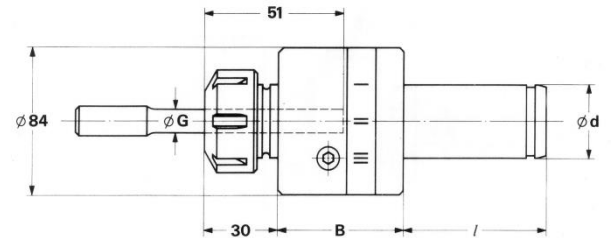

Fig. 35

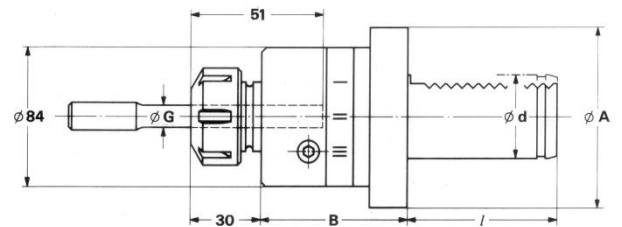

Fig. 36

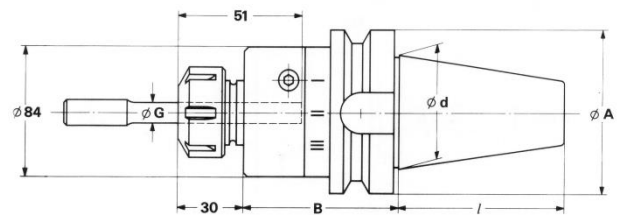

Fig. 37

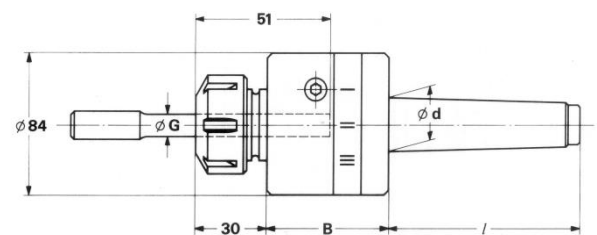

Fig. B

